



DF1101-Ex

AlgoRex
Synova™

Infrared flame detector



Collective/SynoLINE600, for explosion-hazard areas of zone 1 and 2

- **For inside and outside applications**
- **Triple-sensor evaluation**
 - Detection in various wavelengths
 - Microprocessor-controlled signal evaluation
- **Selective evaluation of flicker frequency**
- **Selectable application algorithms**
- **Excellent immunity to false alarms thanks to a combination of patented fuzzy logic and Wavelet analysis**
- **Highest resistance to**
 - electromagnetic influence
 - sunlight and heat radiation
 - humidity and corrosion
- **Wide operating temperature range**
- **Connection to the detection line via the DC1192 input/output module**
 - for galvanic isolation in collective/SynoLINE600 fire detection systems
 - for galvanic isolation and connection to the interactive or AnalogPLUS/SynoLOOP fire detection system

Characteristics

- **Environmental**

- ecologically processing
- recyclable materials
- electronic and synthetic material simple separable

- **Characteristics**

- the detector housing made of aluminum also serves as a screen against electromagnetic interference (EMB)
- the base housing consists of a robust, glass-fiber reinforced synthetic material
- protected electronics
- built-in alarm indicator (AI)
- collective signal processing

- **Explosion protection category**

- The infrared flame detector DF1101-Ex is designed to the explosion protection category 'Intrinsic safety' EEx i. The standards which cover this are EN50014 (IEC60079-0) und EN50020 (IEC60079-11)

Function

- Patented signal evaluation

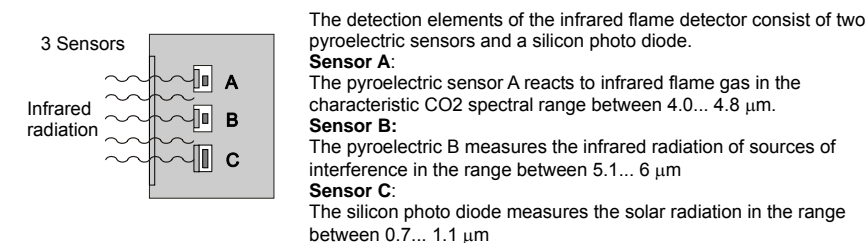
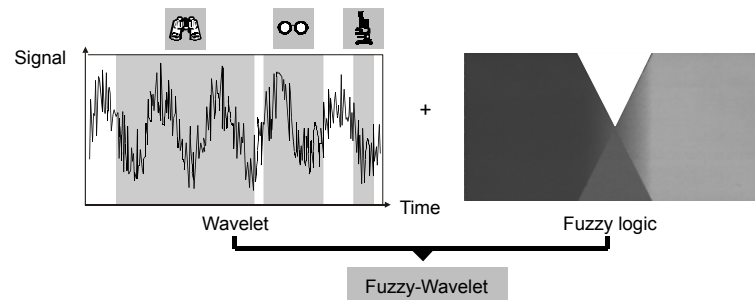

- One sensor measures the hot carbon dioxide in a specific flame wavelength; the two other sensors simultaneously measure the interference radiation in other wavelengths.
- With intelligent signal processing through fuzzy algorithms and wavelet analysis, the DF1101-Ex achieves excellent detection reliability while maintaining the highest immunity to interference radiation and sunlight.
- In order to safeguard against a possible decision emergency, the detector contains an additional emergency activation channel.

- **Application**

- Chemicals production plants
- Chemicals stores
- Oil refineries
- petrol storage and pump stations
- Natural gas transfer points
- Propane and butane filling installations
- All explosion-hazard areas in which flaming fires involving carbonaceous materials are to be expected

Installation in explosion-hazard areas

Equipment installed in explosion-hazard areas must always comply with local national regulations.

The DC1192 input/output module and the series-connected SB3 shunt Zener diode barrier are used as a galvanic isolation between explosion-hazard and non-hazardous areas.

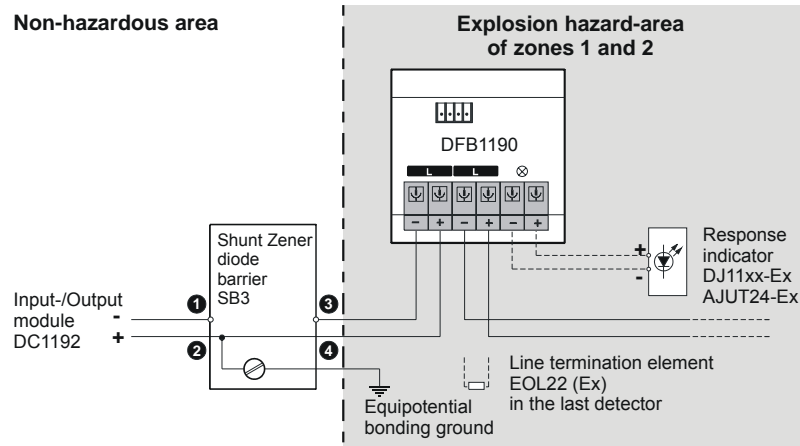

Further details can be found in the documents

- 'Fire protection in explosion-hazard areas', document no. 1204
- 'Input/output module DC1192', document no. 001571

Accessories

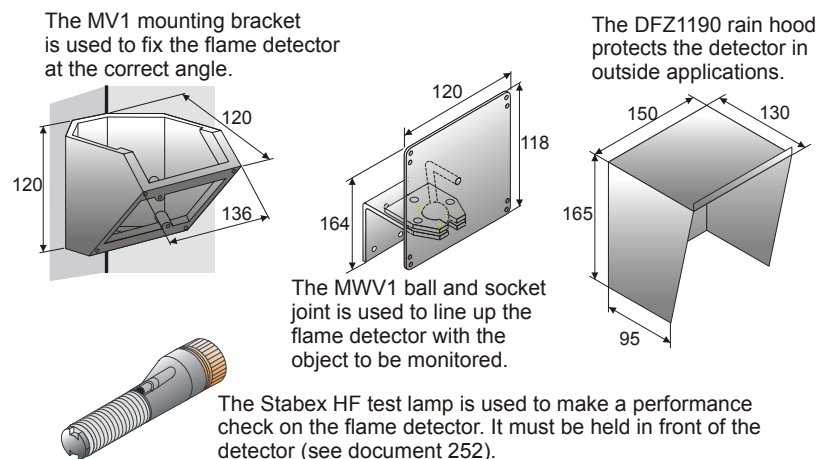

Design

- easy installation of the housing on stable, vibration-free surfaces; the detector is only inserted after installation check, shortly before commissioning
- 6 threads M20 for screwed cable glands
- connection via two-wire installation with the control unit
- ext. alarm indicator connectable
- pluggable connection between flame detector and base
- mounting bracket MV1 for room surveillance to fix the detector at the right inclination angle
- ball and socket joint MWV1 for the orientation to an object
- rain hood DFZ1190 for outside applications

Dimensions

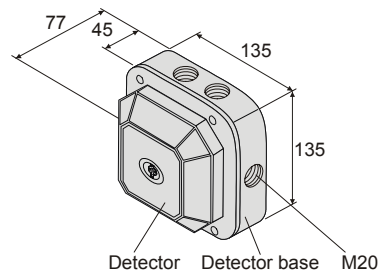

Technical data

Operating voltage	16... 28 VDC
Operating current (quiescent)	0.5 mA
Alarm indicator (AI) ext. connectable and programmable	2
Operating temperature	-35... +70 °C
Storage temperature	-40... +75 °C
Humidity (no heavy condensation of window)	≤95 % rel.
Connection factor KMK	6
Connection terminals	0.2... 2.5 mm ²
Color	white, RAL 9010
Protection category EN60329 / IEC529	IP67
Standards	
– for flame detector	EN54-10
– for explosion-hazard areas	EN50014 (IEC60079-0), EN50020 (IEC60079-11)
Ex classification	II 2 G EEx ib IIC T4 (-35 °C ≤Ta ≤70 °C)
Approvals	VdS Nr. G299085, PTB 02 ATEX 2161, LPCB 126s/03
Compatibility	By using the DC1192 it is compatible with fire detection system control units with collective/SynoLINE600, interactive or Analog-PLUS/SynoLOOP signal evaluation.

Details for ordering

Type	Part no	Designation	Weight
DF1101-Ex	5166750001	Infrared flame detector	0.500 kg
DFB1190	5165360001	Base	0.250 kg
–	A5Q00004478	Screwed cable gland M20 x 1,5	0.039 kg
MV1	3950450001	Mounting bracket	0.285 kg
MWV1	3674840001	Ball and socket joint	0.860 kg
DFZ1190	5302660001	Rain hood	0.640 kg
Stabex HF	4620910001	Test lamp	0.250 kg

Siemens Switzerland Ltd
 Building Technologies Group
 International Headquarters
 Fire Safety & Security Products
 Gubelstrasse 22
 CH-6301 Zug
 Tel. +41 41 724 24 24
 Fax +41 41 724 35 22
www.sbt.siemens.com

© 2007 Copyright by
 Siemens Switzerland Ltd
 Data and design subject to change without notice.
 Supply subject to availability.