



Cerberus® AlgoRex

Automatic fire detectors

DO1100-Ex
DT1100-Ex

Collective, for explosion-hazard areas of zones 1 and 2

- **High degree of reliability and stability**
- **High resistance to:**
 - electromagnetic interference
 - humidity and corrosion
- **Connection to the detection line via the DC1192 input/output module:**
 - for galvanic isolation in collective fire detection systems (suitable for Cerberus and non-Cerberus control units)
 - for galvanic isolation and connection to the interactive or AnalogPLUS Cerberus fire detection system
- **Comprehensive final examination and quality control**
- **Environmentally safe material**
 - halogen-free plastic material identifiable through embossed code
 - easy to uninstall and disassemble



Wide spectrum smoke detector DO1100-Ex Series

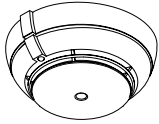

Application

- **Uniform response behaviour for different types of fire**
- **New, high performance optoelectronic sensor system**
- **High resistance to soiling and temperature fluctuation**

For the early warning of smoke-forming flaming fires and smouldering fires in explosion-hazard areas of zones 1 and 2.

Functions

Danger signal. Penetrating smoke scatters the light of an infrared beam in the detector. If the light scatter exceeds a certain value, the detector transmits a danger signal to the control unit.

Built-in response indicator provides on-site signalling of alarm.

Heat detector DT1100-Ex Series

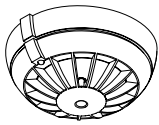

Application

- **Response behaviour immune to deceptive phenomena with rapid and slow increases in temperature**
- **Intelligently designed differential characteristics**
- **Maximum temperature alarm activation with quality thermosensor**
- **Reliable heat detector for demanding requirements:**
 - **DT1101A-Ex: Class 1 heat detector with wide application range (up to +50°C)**
 - **DT1102A-Ex: Heat detector for high ambient temperatures (up to +70°C)**

For the monitoring of explosion-hazard areas of zones 1 and 2 where in the event of fire, a rapid increase in temperature can be expected, or other types of detector cannot be used due to operational reasons.

Functions

Danger signal. The detector measures the ambient temperature with one NTC thermistor and the detector housing temperature with another NTC thermistor. In this way the detector can rapidly and differentially evaluate an increase in temperature independent of the starting temperature.

Built-in response indicator provides on-site signalling of alarm.

Design

Mounting with detector base DB1101A.
Range of base accessories for installation even in critical locations.
Connection to the control unit via a two-wire line.
Vibration-proof mounting of detector in the base.
Anti-theft device if required.
One external response indicator can be connected.

Explosion protection category

DO1100Ex and DT1100Ex fire detector series are designed to the explosion protection category „Intrinsic safety“ EEx i. The standards which cover this are IEC60079 and EN50020.

Installation in explosion-hazard areas

Equipment installed in explosion-hazard areas must always comply with local national regulations.

The DC1192 input/output module and the series-connected SB3 shunt Zener diode barrier are used as a galvanic isolation between explosion-hazard and non-hazardous areas.

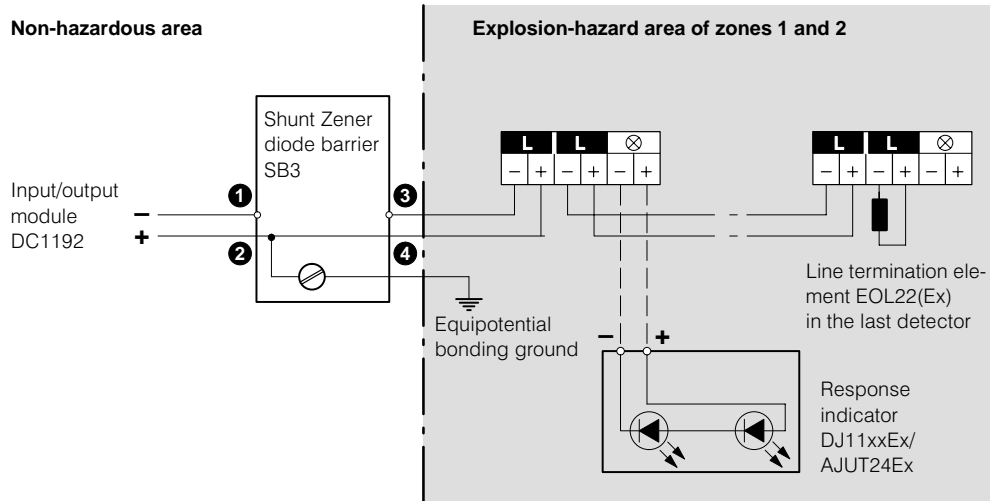

Further details

can be found in the documents:

- „Fire protection in explosion-hazard areas”, no. e1204 with current index
- „Input/output module DC1192”, no. e1571

Maintenance

DO1100-Ex, DT1100-Ex

Detectors can be inserted and removed from their bases with a detector exchanger up to a height of 7m.

DO1100-Ex

By means of a periodic factory overhaul (cleaning and re-calibration), smoke detectors are given a new lease of life.

Dimensions

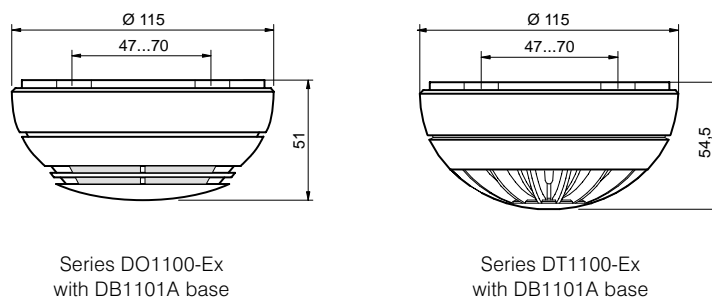

Technical data

	DO1101A-Ex	DT1101A-Ex	DT1102A-Ex
Operating voltage	17...24V _{DC}	16...24V _{DC}	16...24V _{DC}
Operating current (quiescent)	max. 100μA	max. 100μA	max. 100μA
Operating temperature	-25...+60°C	-25...+50°C	-25...+70°C
Humidity			
- ≤34°C	≤95% r.h.	≤100% r.h.	≤100% r.h.
- >34°C	≤35g/m ³ abs.	≤35g/m ³ abs.	≤35g/m ³ abs.
Protection category	IP44	IP44	IP44
Colour	white ≈RAL9010	white ≈RAL9010	white ≈RAL9010
Standards			
- for fire detectors	EN54-7/9	EN54-5, response grade 1	EN54-8, temperature range 1
- for explosion-hazard areas	IEC60079, EN50020	IEC60079, EN50020	IEC60079, EN50020
Ex classification	EEx ib IIC T4 (T _a ≤60°C)	EEx ia IIC T4	EEx ia IIC T4
Ex approvals			
- PTB No.	Ex-96.D.2060	Ex-95.D.2148	Ex-95.D.2148
- ESTI No.	96.1 10358	95.1 1101A3	95.1 1101A3
- VdS	G296052	G296019	G296019
Connection factor	KMK 1.6	KMK 1.0	KMK 1.0
Compatibility	By using the DC1192 input/output module it is compatible with all Cerberus fire detection system control units with collective, interactive or AnalogPLUS signal evaluation		
QS standards	Fire protection industry certified quality assurance system according to ISO9002, EN29002		

Details for ordering

Type	Part no	Designation	Weight
DO1101A-Ex	500801	Wide spectrum smoke detector	0.130kg
DT1101A-Ex	485214	Heat detector	0.105kg
DT1102A-Ex	485227	Heat detector	0.105kg
DB1101A	486365	Base, collective	0.055kg

For base accessories see sheet DB11 Series, e1035

