



Illuminated warning panel

LTEX24.1

For explosion-hazard areas in zones 1 and 2

The illuminated warning panel indicates that permanent, automatic FM200 or CO₂ extinguishing systems are about to be or already have been actuated.

The illuminated warning panel comprises a plastic housing with a Plexiglass cover and contains two 24V/10W incandescent lamps and two terminals. The „GAS/GAZ” transparency is illuminated by the two incandescent lamps which are connected in parallel. The device complies with protection category for increased security „e”.

Note the following points when handling the device:

- Only install the device when the power supply is switched off.
- For cable entries, use the built-in Ex „e” certified PG11 screwed cable gland.
- Connect the wires to both terminals.
- Only apply voltage when the cover is closed.
- Only open the device for repair and servicing when the power supply is switched off.
- To avoid electrostatic charges, only clean the device with a damp cloth.

Dimensions

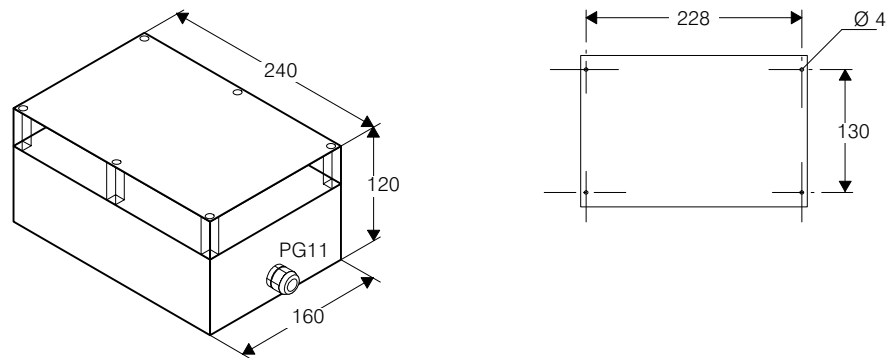

Connection diagram

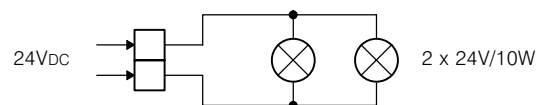

Technical data

Manufacturer's designation	8195 NO/Ex/2x24
Operating voltage	24Vdc
Incandescent lamps	2 x 24V/10W
Lamp holders	E14
Ambient temperature	-20 ... +40°C
Storage temperature	-25 ... +75°C
Permissible humidity	≤100% r.h.
Housing	
- material	Makrolon
- protection category	IP54
- colour	light grey, ≈RAL7035
Ex classification	Ex II 2 G Ex edms IIC T4
Approval (only for Switzerland)	SEV no. 99.1 10338

Details for ordering

Type	Part no	Designation	Weight
LTEX24.1	487199	Illuminated warning panel	1.825kg

